

2" SCA Laser Collimator configuration

2" SCA adapter + 1.25" SCA Laser Collimator

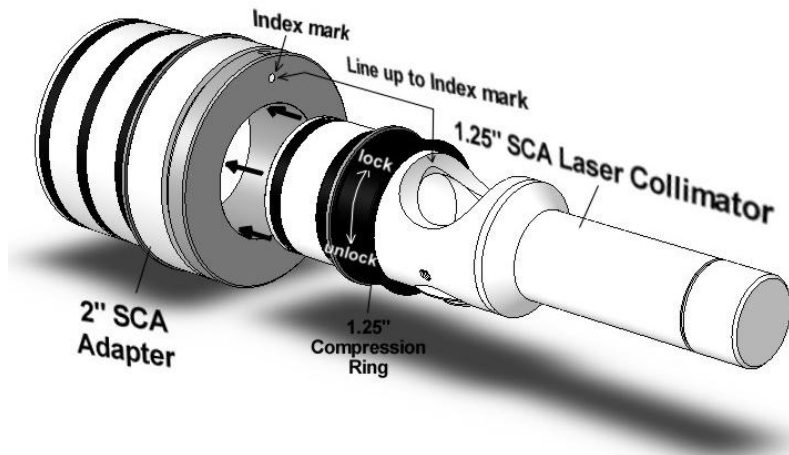

Specification:

- Output power : Class II, <1mW
- Wavelength: 650nm
- Operating temperature & humidity: 15°C ~ 40°C - < 70% relative humidity
- Storage temperature & humidity: -10°C ~ 60°C - < 70% relative humidity
- Battery: One 3V Lithium CR123
- Weight: apx. 1.25" @ 0.2 lb., 2" @ 0.4 lb. w/ battery
- Battery life: Up to 40 hours
- Collimator Dimension: 1.25" - 4.9" Length
2" - 6.0" Length

Detaching 1.25" SCA laser collimator from the 2" SCA Adapter:

1. Unthread the 1.25" compression ring in the counter-clock direction until the ring stops.
2. Press and step the 1.25" SCA Laser Collimator toward the 2" SCA adapter (see above illustration arrow direction), then pull out the laser.
The small step relieves the expanded rubber rings to none compression form, so it can be easily remove from the 2" adapter.

Installing 1.25" SCA laser collimator into the 2" Adapter:

1. Install the 2" SCA Adapter itself into a focuser using the same method described in the Newtonian Instruction sheet. Make sure the adapter is flush against the rim of your focuser or visit www.youtube.com/hotechusa for a video guide.
2. Insert and orient the 1.25" SCA Laser Collimator's target window face up corresponding to the index mark on the 2" SCA Adapter as in the illustration above. Then press the 1.25" SCA Laser Collimator flush against the 1.25" opening on the 2" SCA Adapter.
3. Thread the 1.25" compression ring to lock the laser in the 2" SCA Adapter. Check if the laser is installed properly by activating the laser and rotate the entire 2" SCA Adapter in the focuser and see if the laser dot is circling in the same place on your primary.
4. If the laser dot is circling in a large circle, the laser is not adapted properly. Loosen the 1.25" compression ring and press the 1.25" adapter flush against the 2" Adapter, hold on to the viewer section of the laser collimator, and tighten the 1.25" compression ring again. Repeat the step if the laser dot is still circling in a large circle. For more information please visit our website at www.hotechusa.com/collimator.html.

Utilizing the number marked targeting grid:

The targeting grid has three thick lines with one, two and three dot(s) on the end of each line. Use the marked lines to correspond to your primary alignment screws. E.g. Install the collimator and turn on the laser. Adjust one of the primary alignment screws to see which direction the laser moves on the target grid. Orient the marked line to the corresponding moving direction. Then the other two numbered line will automatically correspond to the other two primary mirror alignment screws. You may also mark down the corresponding number on the primary alignment screws. The matching numbering on the corresponding screw and target line helps you greatly in adjusting the correct screw during primary mirror collimation.

Maintenance:

1. If the SCA Laser Collimator is not to be used for an extended period of time, unload the battery to prevent possible damage from leaking battery.
2. After each use, wipe entire surface with a soft, dry cloth to prevent damage from perspiration accumulation.
3. Store the SCA Laser Collimator in its case, or sealed in a dry clean place, to prevent the lens from accumulating any dust or contaminants.
4. To clean the collimator, use an air spray to blow the front of the laser and wipe with a clean towel or cotton stick. Do not open the collimator. Call or email us if you have any question at info@hotechusa.com.

Q&A: The SCA adapter collimator stuck in the eyepiece holder.

Relief the rubber rings by unthreading the compressing ring in the unlock direction. Press the collimator back into the eyepiece holder. Gently pull straight out the collimator. If still bites in the eyepiece holder, repeat this process again, or visit www.youtube.com/hotechusa for video guide.

Q&A: The SCA adapter cannot tightly fit in the eyepiece holder.

Your eyepiece holder's diameter is larger than standard tolerance. You may need to use your thumbscrew to slightly hold the laser collimator in place. The laser will not be perfectly centered but it has taken out most of the tolerances and keeps the laser close to your telescope's optical center or visit www.youtube.com/hotechusa for video guide.

Q&A: The laser does not turn ON.

Check if your battery is fresh or installed correctly (positive side toward the cap) see illustration in page 1. Change new battery if necessary.

Warranty:

SCA Laser Collimator is warranted against defects in material and workmanship for the natural life of the instrument for 1 year after date of invoice. Damage due to accident, alteration, misuse or abuse or damage resulting from repair by unauthorized parties is not covered. Any disassembling of the SCA Laser Collimator will void the warranty. 15% restocking fee may occur when returning the item for refund. Do not expose the SCA Laser Collimator in any dirty, dusty, or wet environment. Do not submerge the SCA Laser Collimator in the water. Exposure to extreme dirt and moisture may cause bad connection and disabling the laser and damaging the laser optics thus void the warranty. Please consult with our technical support personal for any problems you might have at Info@HoTechUSA.com.